

MGB 1100 L DOMED LID

LID IN LID (DL LIL)



EASY FILLING
THROUGH LIGHTWEIGHT SMALLER LID

- 1 // LID IN LID
- 2 // EASY FILLING
- 3 // WIDE APERTURE



MGB 1100 L DOMED LID (DL) IN ACCORDANCE WITH EN 840

- manufactured from HDPE using the compact injection moulding process in accordance with EN 840-3
- sliding lid can be secured in three positions
- simple exchange of the smaller lid
- stepped rim, reinforced by additional ribbing
- chip-nest for secure transponder placement
- galvanised metal parts
- resistant to UV, cold, heat and chemicals
- embossed markings and hot-foil printing available
- standard colours – grey, green, blue and brown
other colours available on request

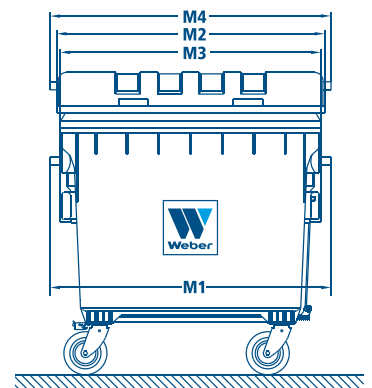
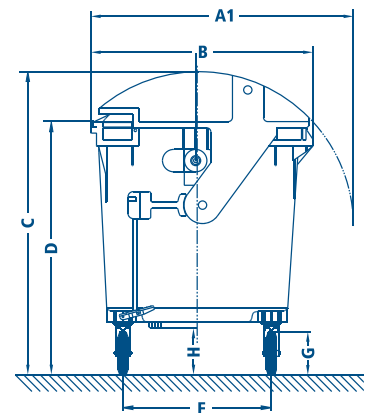

WEBER 4-WHEELED DOMED LID BINS 1100 L	1100 L DL LIL
Nominal volume (l)	1100
Nominal payload (kg)	440
Empty weight ca. (kg)*	68.3
A1 Total depth, lid open (mm)	1220
B Body, total depth (mm)	1065
C Total height (mm)	1460
D Body, height (mm)	1205
F Travelling gear, width (mm)	755
G Wheel Ø (mm)	200
H Ground clearance (mm)	225
M1 Width with lifting trunnions (mm)	1372
M2 Lid, width (mm)	1270
M3 Body, width (mm)	1200
M4 Width with lid trunnions	1370

Customer field 370 x 49 mm for all 4-wheeled bins (customer name or blank)

* Empty weight ca. (kg) with lifting trunnions

We reserve the right to make dimensional and constructional alterations.

