



BALING and COMPACTION SOLUTIONS

for optimising transportation

PAAL®

PACOMAT
Baler Range

Offering a wide range of auto tie baler and compaction equipment

KADANT

PAAL®



PACOMAT

Where simplicity, efficiency and performance are key



The D series is the most recent generation of the Pacomat range of bale presses. The aim of this range is to combine the best performance with the minimum energy consumption.

The use of current technology (energy efficient hydraulic pumps, channel design/construction, cutting knife design) , taking into account the experience and feedback from our many customers worldwide, enabling greater bale densities to be produced from very low energy consumption.

Bale density has increased, wire consumption is proportionally reduced, with improved weights for transportation. Profitability is therefore better while reducing the carbon footprint.

Kadant PAAL's principle

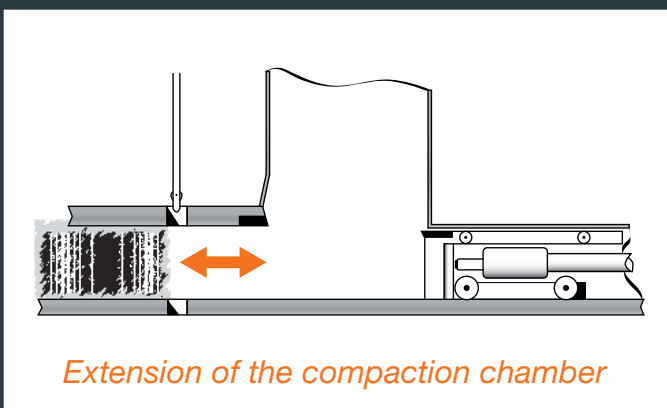

The dimensions of the compaction chamber allow the separation between the cutting operations of the material and its compaction. The main cylinder applies 100% of its force at the time of cutting and then to compact the bale, being denser and consuming less energy.

The MULTIPURPOSE baler

The Pacomat press has been researched and developed to meet the most varied and challenging of applications.

Its many options enable it to meet high throughput capacity requirements expected by our customers. With this comes robust design and a high level of reliability. The baler is simple to operate, maintenance is made easy by providing many access doors, unique for a baler of this size, making the Pacomat ideal for logistics/distribution centres or any similar applications requiring impressive performance within a budget.

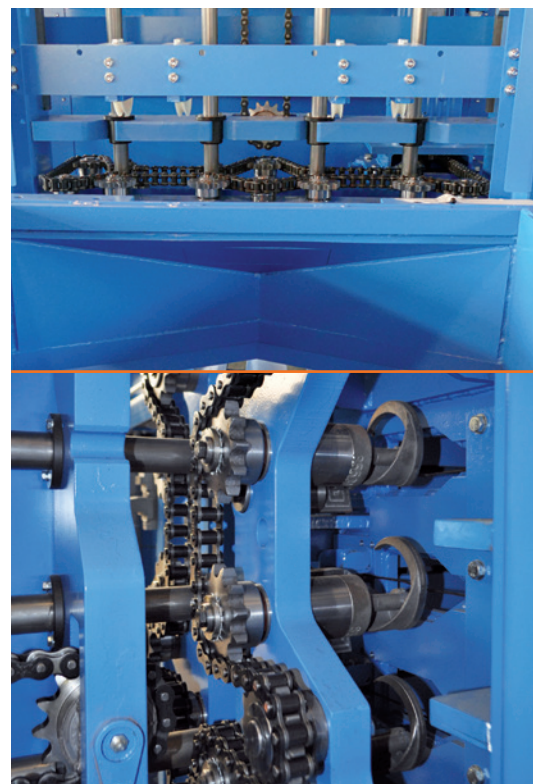

Horizontal tying

for easy access from
the ground

Vertical tying

to occupy less space



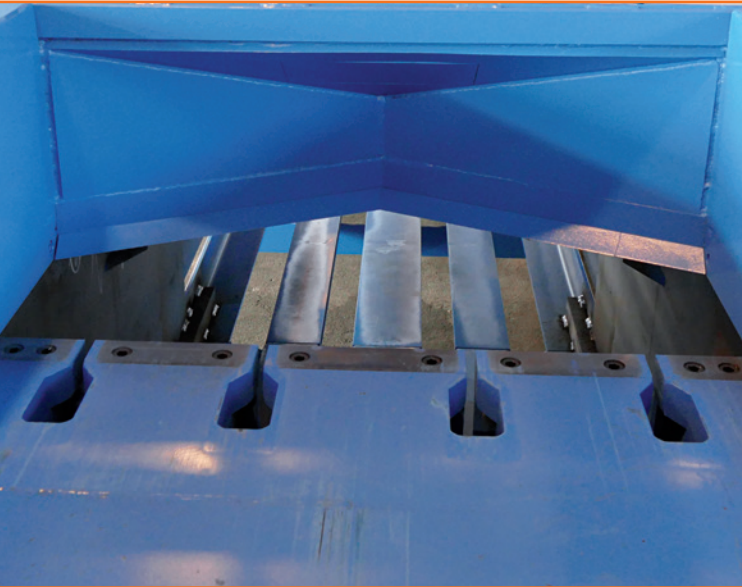

Cost effectiveness

All factors are considered and used to guarantee the best material bale density and profitable baling solution.

The most profitable

From the conception of the baler, the maintenance points are easily accessible. This increases the productivity including the life expectancy of the machine.

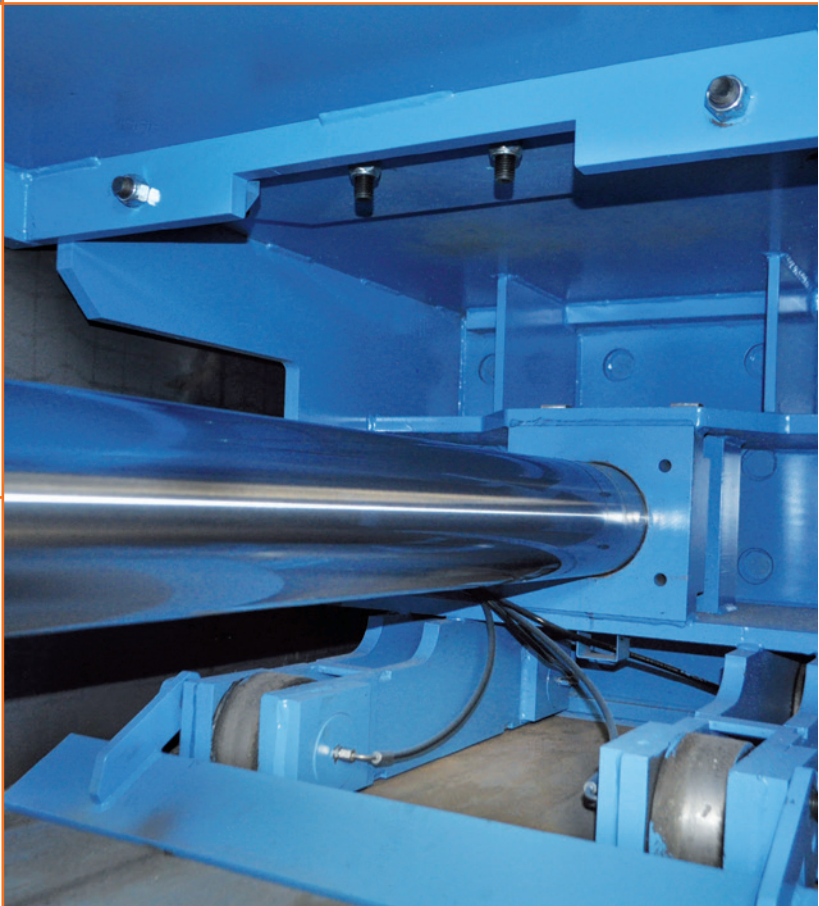

Did you know

All wear parts of the pressure plate are accessible through the large side doors.



Security

Its graphical and intuitive interface, as well as all the standard security elements, allows a simple and safe use



Smart solutions

- 1 The cable channel is open and mounted upside down preventing rodent damage.
- 2 Independent and grouped greasers, practical and efficient.
- 3 Quick and patented connection of the cylinder with the presser plate and ensuring easy maintenance.



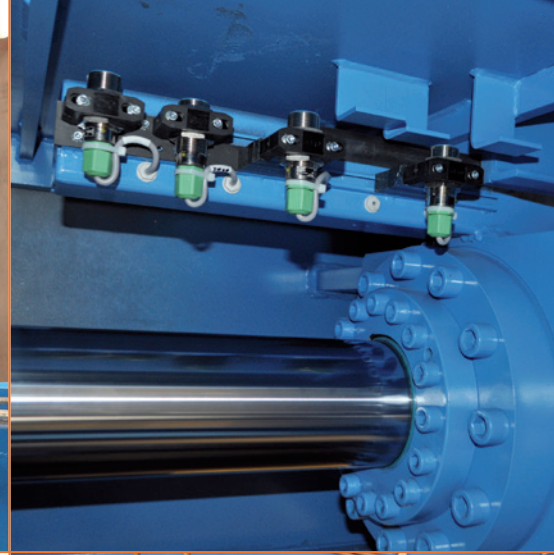
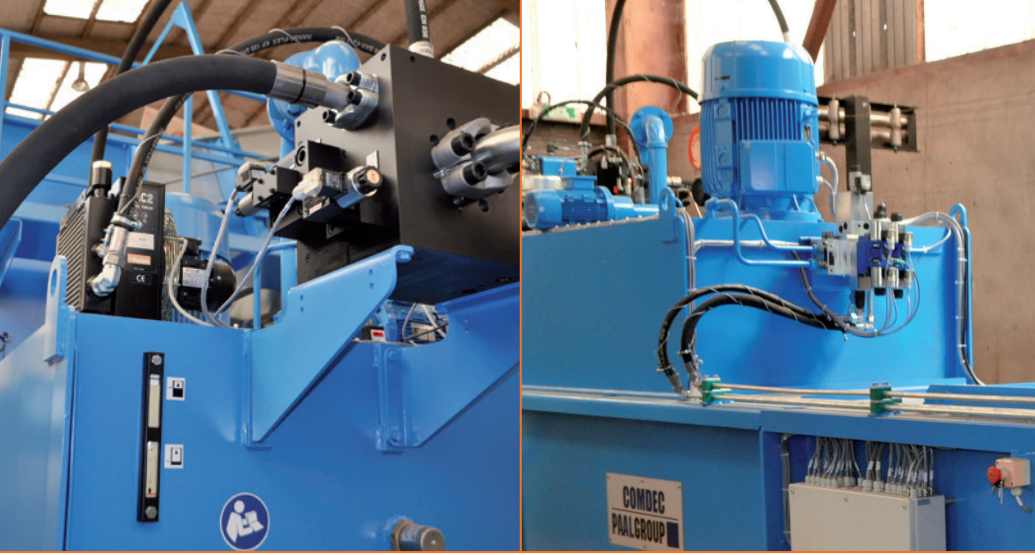

NEW technologies

The use of state-of-the-art components provides high performance with minimal energy consumption.

The hydraulic block mounted directly on the back of the baler to minimise movement and energy loss.

Axial and submerged piston pumps provide higher performance than older pumps, consuming less energy.

The use of a real time, non contact, pressing plate position measurement system optimises the filling of the hopper, bale length and bale density.

It's also makes it possible to maximise the force of compaction, producing better bale density with less power being consumed.



The Key to versatility

Manufactured on a common basis, the PACOMAT balers can be equipped with numerous options according to your needs.

- 1 Perforator integrated in the feeding hopper
- 2 Ruffler for opening magazines or newspapers packs
- 3 Hopper with fixed or folding chute
- 4 Automatic cutting edge stamper
- 5 Digital panel indicative of large figures for better viewing of signals from the press (parameters, alarms, ...)

In the same way :

- Remote control for a sorting plant, controlling the storage of each cell
- Remote diagnostic maintenance
- Detection of absence of wire

These are some of the options available/most used

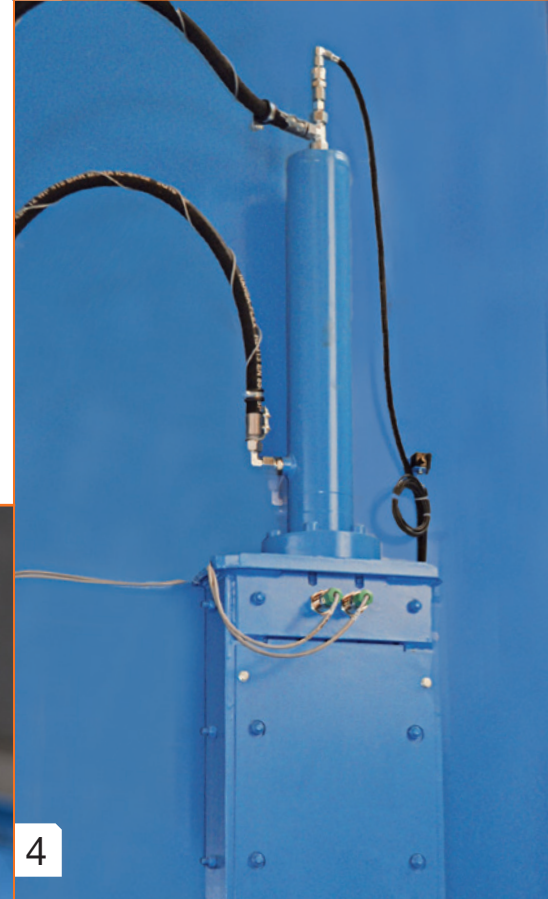

Bale section 750 x 1100

PACOMAT III

Horizontal tying

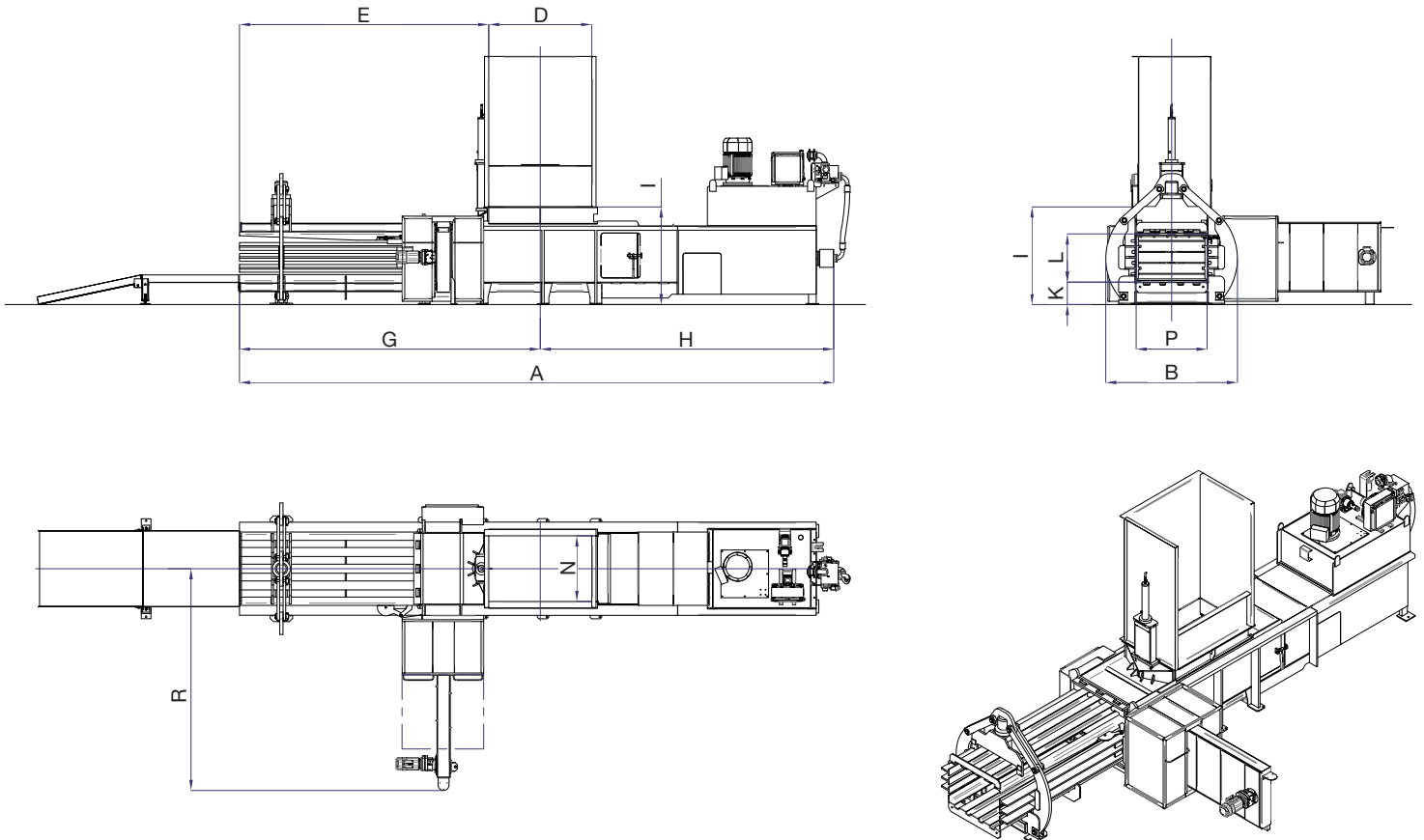

Dimensions in mm	A	B	D	E	G	H	I	K	L	N	P	R
PACOMAT III-50 D	8172	2030	1250	3475	4100	4072	1475	310	750	1020	1100	3445
PACOMAT III-65 D	8826	2030	1450	3720	4445	4381	1475	310	750	1020	1100	3445
PACOMAT III-80 D	9410	2044	1600	3870	4670	4740	1515	350	750	1020	1100	3445

Standard paint colours :



Blue RAL 5012

Other colours are available on request.



Green RAL 6011

Technical Specifications

PACOMAT III

MODEL		III-50 D				III-65 D						III-80 D							
Compaction force	t (kN)	50 (486)				65 (633)						82 (802)							
Specific pressure	N/cm ²	59				77						97							
Hydraulic reference pressure	bar	314				314						314							
Dimensions of the bales	mm	ht 750 x larg. 1100				ht 750 x larg. 1100						ht 750 x larg. 1100							
Hopper opening	mm	1 250 x 1020				1 450 x 1 020						1 600 x 1 020							
Feed volume	m ³	1,55				1,75						1,85							
Number of wires horizontal	--	4				4						4							
Number of wires vertical	--	Non available				Non available						Non available							
Number of wires in cross tie	--	Non available				Non available						Non available							
Wire diameter accepted	mm	3 to 3,4 (standard 3,2)				3 to 3,4 (standard 3,2)						3 to 3,4 (standard 3,2)							
Accepted wire quality	--	Black wire annealed, lubricated, according to EN10016-2				Black wire annealed, lubricated, according to EN10016-2						Black wire annealed, lubricated, according to EN10016-2							
Motor	kW	15	22	37	45	15	22	37	45	55	75	15	22	37	45	55	75	2x37	2x45
Hydraulic pump flow	l/mn	160	160	260	260	160	160	260	260	420	420	160	160	260	260	420	420	520	520
Oil reservoir capacity	l	550	550	750	750	550	550	750	750	1250	1250	550	550	750	750	1250	1250	1250	1250
Maximum performance without material	m ³ /h	422	422	617	617	339	339	505	505	742	675	275	275	416	416	624	624	741	741
Maximum performance with material (material 35 Kg / m ³)	m ³ /h	147	182	274	298	125	154	237	258	337	381	107	132	205	224	297	337	365	393
THROUGHPUT																			
35 kg/m ³ (corrugated cardboard)	t/h	5,1	6,4	9,6	10,4	4,4	5,4	8,3	9	11,8	13,3	3,8	4,6	7,2	7,8	10,4	11,8	12,8	13,8
50 kg / m ³ (mixed paper)	t/h	6,9	8,6	12,8	14	5,9	7,3	11,1	12,2	15,6	17,7	5	6,3	9,8	10,8	14	16,1	17,2	18,7
80 kg / m ³ (mixed paper)	t/h	10	12,7	19	21	8,3	10,6	16	17,7	22	25,4	7,5	9,4	14,5	15,9	20,3	23,3	24,7	26,8
Baler weight (dependent on options)	t	12				13						17							
Sound level without material at 1 m dB (A)	dB(A)	< 85				< 85						< 85							

Lay out and characteristics are susceptible to change without prior notice.



PACOMAT

Simplicity, reliability, performance are key



Bale section 750 x 1100

PACOMAT V

Horizontal tying

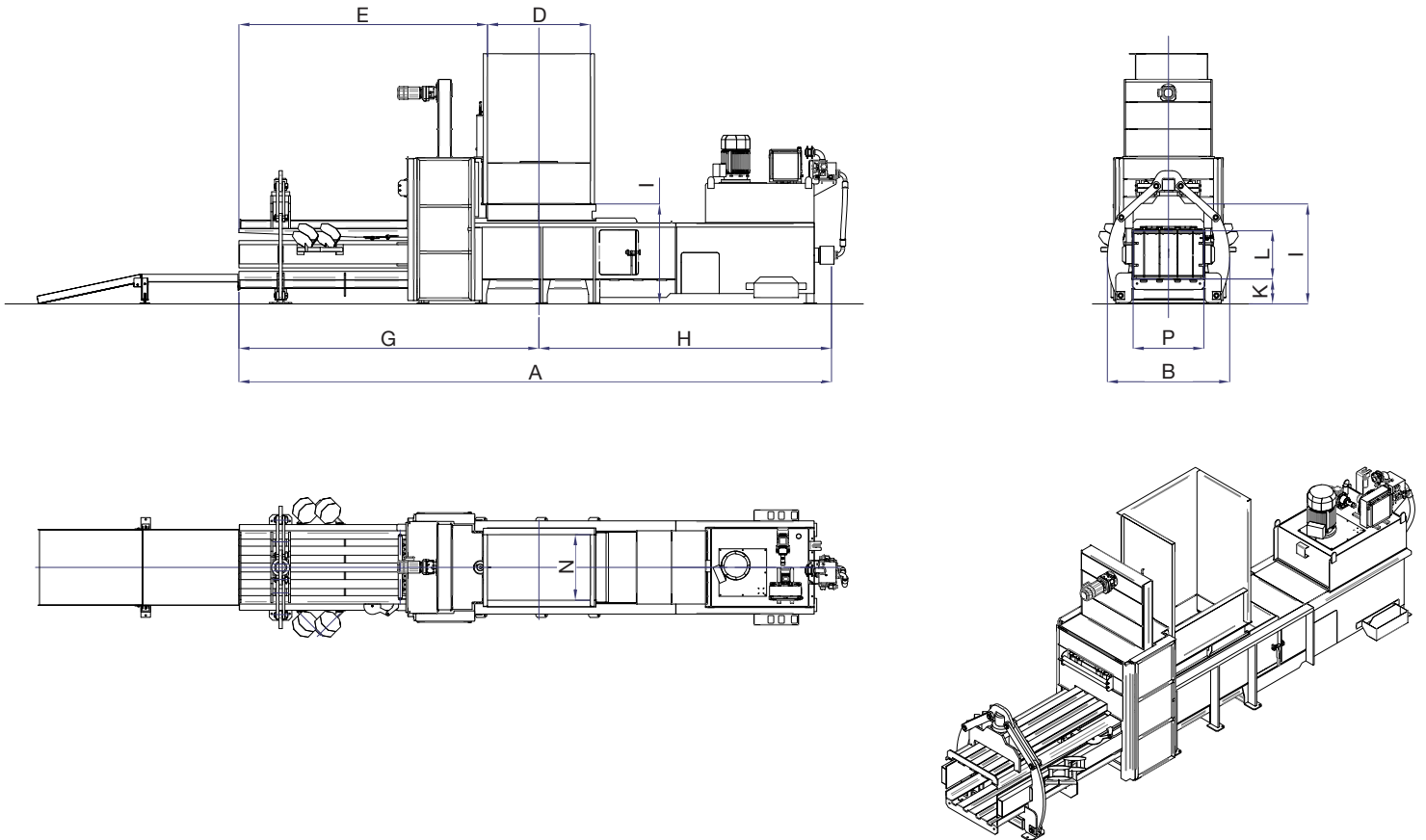

Dimensions in mm	A	B	D	E	G	H	I	K	L	N	P
PACOMAT V-50 D	8212	1915	1250	3475	4100	4112	1515	350	750	1020	1100
PACOMAT V-65 D	8866	1915	1450	3720	4445	4421	1515	350	750	1020	1100
PACOMAT V-80 D	9450	1915	1600	3870	4670	4780	1555	390	750	1020	1100

Standard paint colours :



Blue RAL 5012

Other colours are available on request.



Green RAL 6011

Technical Specifications

PACOMAT V

MODEL		V-50 D				V-65 D						V-80 D							
Compaction force	t (kN)	50 (486)				65 (633)						82 (802)							
Specific pressure	N/cm ²	59				77						97							
Hydraulic reference pressure	bar	314				314						314							
Dimensions of the bales	mm	ht 750 x larg. 1100				ht 750 x larg. 1100						ht 750 x larg. 1100							
Hopper opening	mm	1 250 x 1020				1 450 x 1 020						1 600 x 1 020							
Feed volume	m ³	1,55				1,75						1,85							
Number of wires horizontal	--	Non disponible				Non disponible						Non disponible							
Number of wires vertical	--	4				4						4							
Number of wires in cross tie	--	Non available				Non available						Non available							
Wire diameter accepted	mm	3 to 3,4 (standard 3,2)				3 to 3,4 (standard 3,2)						3 to 3,4 (standard 3,2)							
Accepted wire quality	--	Black wire annealed, lubricated, according to EN10016-2				Black wire annealed, lubricated, according to EN10016-2						Black wire annealed, lubricated, according to EN10016-2							
Motor	kW	15	22	37	45	15	22	37	45	55	75	15	22	37	45	55	75	2x37	2x45
Hydraulic pump flow	l/mn	160	160	260	260	160	160	260	260	420	420	160	160	260	260	420	420	520	520
Oil reservoir capacity	l	550	550	750	750	550	550	750	750	1250	1250	550	550	750	750	1250	1250	1250	1250
Maximum performance without material	m ³ /h	422	422	617	617	339	339	505	505	742	675	275	275	416	416	624	624	741	741
Maximum performance with material (material 35 Kg / m ³)	m ³ /h	147	182	274	298	125	154	237	258	337	381	107	132	205	224	297	337	365	393
THROUGHPUT																			
35 kg/m ³ (corrugated cardboard)	t/h	5,1	6,4	9,6	10,4	4,4	5,4	8,3	9	11,8	13,3	3,8	4,6	7,2	7,8	10,4	11,8	12,8	13,8
50 kg / m ³ (mixed paper)	t/h	6,9	8,6	12,8	14	5,9	7,3	11,1	12,2	15,6	17,7	5	6,3	9,8	10,8	14	16,1	17,2	18,7
80 kg / m ³ (mixed paper)	t/h	10	12,7	19	21	8,3	10,6	16	17,7	22	25,4	7,5	9,4	14,5	15,9	20,3	23,3	24,7	26,8
Baler weight (dependent on options)	t	12				13						17							
Sound level without material at 1 m dB (A)	dB(A)	< 85				< 85						< 85							

Lay out and characteristics are susceptible to change without prior notice.

Reliable, Nationwide Service

Our commitment : to provide the best service possible



Service dept

Centrally based ensuring quick response.

01773 520565 option 3



Location

Highly trained service engineers strategically based across the UK.



Service contracts

Maintenance contracts, including spare parts, with a single objective : That your baler is always in service and well maintained.



Financing

Finance solutions available on request.

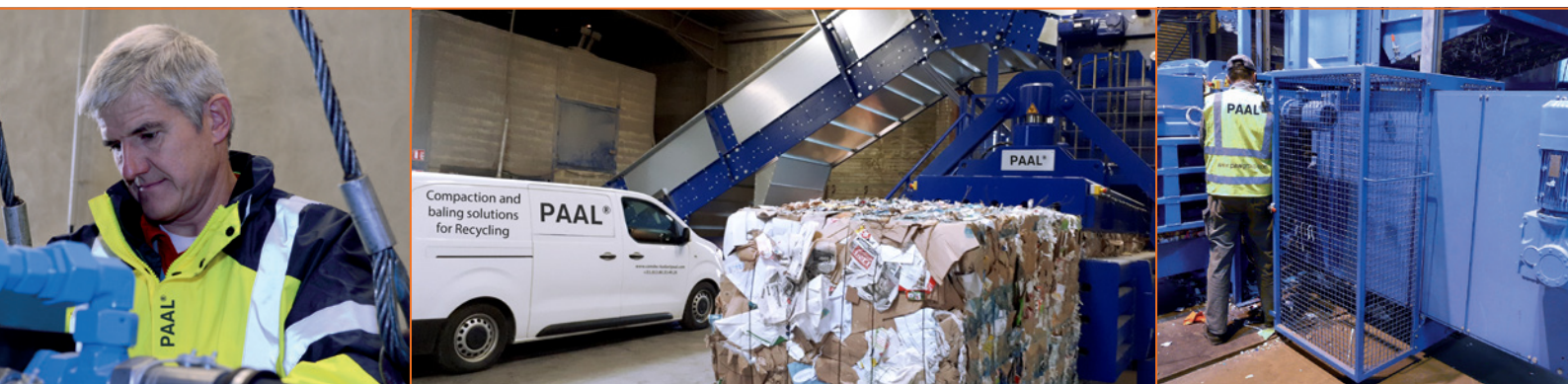

KADANT

Kadant PAAL Ltd.

Lydford Road

Meadow Lane Industrial Estate

Alfreton, DE55 7RQ.

www.kadantpaal.ltd.com

PAAL®