

# Eggersmann Forus FK 38

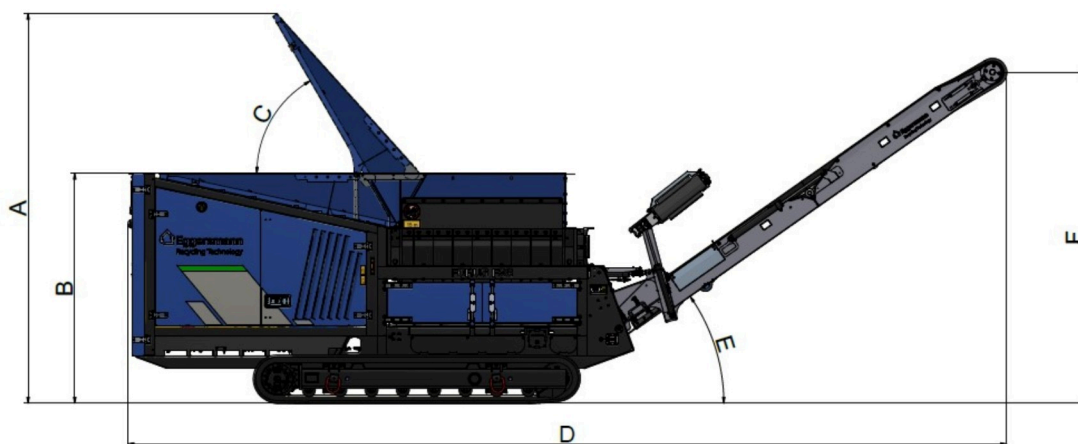

Dimensions work			
Length	D	mm / ft	10,890 / 35'7
Width	L	mm / ft	2,550 / 8'4
Height	A	mm / ft	4,830 / 15'8

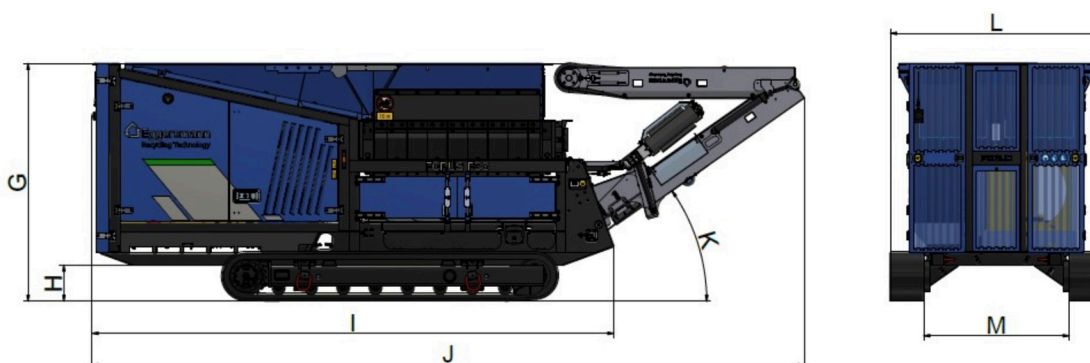

Dimensions transport			
Length	J	mm / ft	8,560 / 28'1
Width	L	mm / ft	2,550 / 8'4
Height	G	mm / ft	2,860 / 9'4
Ground clearance	H	mm / ft	435 / 1'4
Machine chassis	I	mm / ft	6,270 / 20'6
Track width	M	mm / ft	1,750 / 5'7

10.04.2024

# Eggersmann Forus FK 38

Drive			
Engine			CAT C9.3
Power		kW / HP	280 / 380
Emission standard			Tier 4f / EU stage V
Tank capacity		litres / gal (US)	400 / 105
Tank capacity DEF		litres / gal (US)	42 / 11

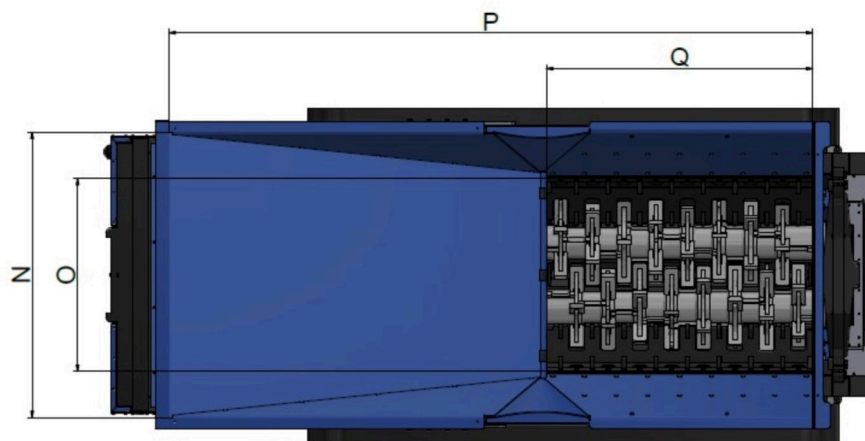

Filling area			
Filling volume		m <sup>3</sup> / yd <sup>3</sup>	7.5 / 9.8
Filling length	P	mm / ft	4,910 / 16'1
Filling width	N	mm / ft	2,150 / 7'1
Filling height	B	mm / ft	2,850 / 9'4
Angle hopper	C	°	60, hydraulically liftable

Shredder unit			
Tools shaft 1 / shaft 2		Pieces	40 / 40
Speed shredding shafts		U/min / rpm	5-35, individually driven, asynchronous
Length shredder unit	Q	mm / ft	2,040 / 6'7
Width shredder unit	O	mm / ft	1,480 / 4'9
Ø Shredding shafts		mm / ft	240 / 0'9 (flight circle 670 / 2'2)

10.04.2024

# Eggersmann Forus FK 38

Conveyor			
Width discharge belt		mm / ft	1,200 / 3'9
Discharge height	F	mm / ft	3,250 – 4,100 / 10'7 - 13'5
Angle discharge belt	E	°	25 - 35
Overbelt magnet		mm / ft	1,820 x 700 / 6'0 x 2'3 400 / 1'3 hydraulically height adjustable

Frame		
		Track drive with triple bar grouser shoe
Axle distance	mm / ft	3,470 / 11'4
Chassis width	mm / ft	2,550 / 8'4
Total machine weight	kg / lbs	19,500 / 42,990

Electronics	
	24V Eggersmann <b>OneLogic</b> machine and drive control

Varnishing		
Machine		RAL 5010 blue
Chassis		RAL 9005 black
Conveyor frame		RAL 7040 grey
Layer thickness	µm	> 120

10.04.2024